

THE GENERAL RADIO  
**EXPERIMENTER**

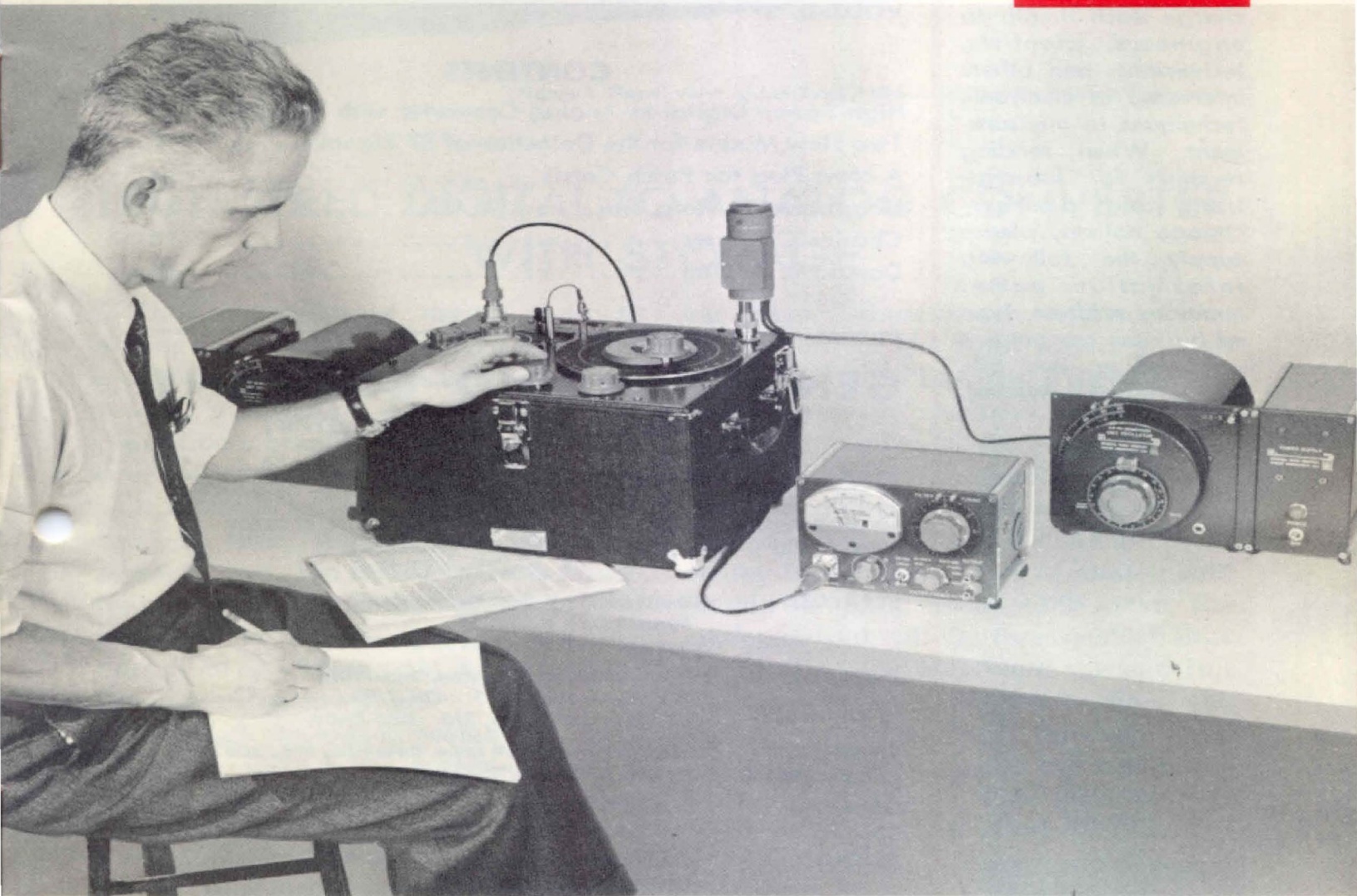

VOLUME 37 No. 12

DECEMBER, 1963

**GENERAL RADIO COMPANY**  
extends to all *Experimenter* readers  
its best wishes for a  
**Happy and Prosperous 1964**

# EXPERIMENTER



The General Radio EXPERIMENTER is mailed without charge each month to engineers, scientists, technicians, and others interested in electronic techniques in measurement. When sending requests for subscriptions and address-change notices, please supply the following information: name, company address, type of business company is engaged in, and title or position of individual.

©1963—GENERAL RADIO COMPANY, WEST CONCORD, MASS., U.S.A.

Published Monthly by the General Radio Company

VOLUME 37 • NUMBER 12

DECEMBER, 1963

## CONTENTS

	Page
High-Speed Digital-to-Analog Converter with Storage	3
Two New Mixers for the Detection of RF Signals . . . . .	7
A New Plug for Patch Cords . . . . .	14
Handbooks to Help You . . . . .	15
Charles C. Carey . . . . .	16
Donald B. Sinclair . . . . .	16

## GENERAL RADIO COMPANY

West Concord, Massachusetts\*, 01781

Telephone: (Concord) 369-4400; (Boston) 646-7400  
Area Code Number: 617

**METROPOLITAN NEW YORK:**\* Broad Avenue at Linden, Ridgefield, N. J., 07657  
Telephone — N. Y., 212 964-2722  
N. J., 201 943-3140

**SYRACUSE:** Pickard Building, East Molloy Road,  
Syracuse, N. Y., 13211  
Telephone — 315 454-9323

**PHILADELPHIA:** 1150 York Road, Abington, Pa., 19001  
Telephone — Phila., 215 424-7419  
Abington, 215 887-8486

**WASHINGTON\*** Rockville Pike at Wall Lane, Rockville, Md., 20852  
**and BALTIMORE:** Telephone — 301 946-1600

**ORLANDO:** 113 East Colonial Drive, Orlando, Florida, 32801  
Telephone — 305 425-4671

**CHICAGO:**\* 6605 West North Avenue, Oak Park, Illinois, 60302  
Telephone — 312 848-9400

**CLEVELAND:** 5579 Pearl Road, Cleveland, Ohio, 44129  
Telephone — 216 886-0150

**DALLAS:** 2501-A West Mockingbird Lane, Dallas, Texas, 75235  
Telephone — 214 Fleetwood 7-4031

**LOS ANGELES:**\* 1000 North Seward St., Los Angeles, Cal., 90038  
Telephone — 213 469-6201

**SAN FRANCISCO:** 1186 Los Altos Ave., Los Altos, Cal., 94022  
Telephone — 415 948-8233

**TORONTO:**\* 99 Floral Parkway, Toronto 15, Ontario  
Telephone — 416 247-2171

**MONTREAL:** Office 395 1255 Laird Blvd., Town of Mount Royal,  
Quebec  
Telephone — 514 737-3673, -3674

\*Repair services are available at these offices.

GENERAL RADIO COMPANY (OVERSEAS), ZURICH, SWITZERLAND  
REPRESENTATIVES IN PRINCIPAL OVERSEAS COUNTRIES

### COVER



The Type 916-AL Radio-Frequency Bridge with a null detector employing the new Type 1232-P1 RF Mixer, as arranged for measurements at 4 Mc. The mixer is plugged directly into the detector terminals at the rear right-hand corner of the bridge.



Figure 1. Panel view of the Type 1136-A Digital-to-Analog Converter.

## HIGH-SPEED DIGITAL-TO-ANALOG CONVERTER WITH STORAGE

The conversion of digital data to analog form provides both a convenient method of presentation and a permanent record. The analog output can be displayed on a graphic recorder, and whenever the input data changes continuously as a function of some other parameter, such as time, temperature, humidity, pressure, etc., the record permits immediate evaluation. A typical application is shown in Figure 2, where the frequency of a 5-Mc crystal is plotted as a function of temperature.

Although the analog output may have no better than 0.1% accuracy, this is quite sufficient for incremental measurements. If the analog output is formed by 3 digits, the minimum increment is 0.1%. By choice of the appropriate 3 digits of the input, the analog system interpolates between the next significant units of the input data. This is illustrated by the example of Figure 2.

When the analog output is formed from the last 3 digits of an 8-digit counter indicating tenths of cycles per second, the total span of the analog output is 100.0 cps even though the counter may be measuring a 5-Mc frequency. The 0.1% accuracy of the ana-

log output, therefore, is equivalent to 0.1 cps out of the total input, and no accuracy is lost. The first 5 digits of the counter remain constant. When these are of any interest they can be read from the counter's visual display and recorded manually. The analog output interpolates between 4,998,400.0 cps as analog 0 and 4,998,499.9 as analog 999. Should the data exceed 4,998,499.9, the analog output will "automatically" shift its 0 to be 4,998,500.0 and the new full scale would be 4,998,599.9. Since the analog is formed from the last three digits, it is not affected by the digits further to the left. This permits high incremental sensitivity without danger of full-scale current being exceeded.

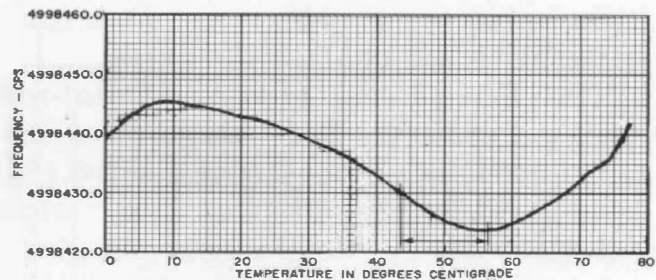

Figure 2. Frequency-vs-temperature characteristic of 5-Mc crystal. Full scale for analog curve was 100 cps, each minor division 1 cps. Only the significant part of the analog record (from 4998420.0 to 4998460.0) is reproduced here. Gate time was 10 seconds.

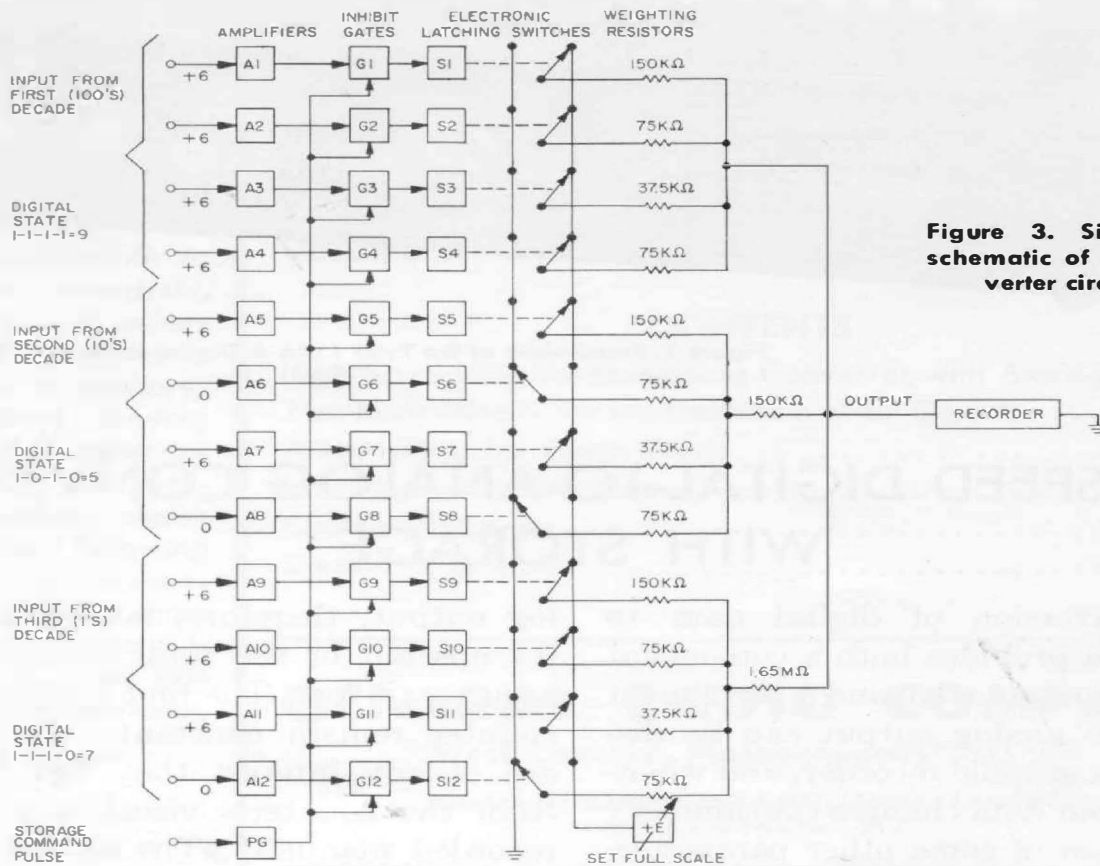

Figure 3. Simplified schematic of the converter circuit.

At GR the advantages of analog recording have long been recognized, and the TYPE 1134-A Digital-to-Analog Converter<sup>1</sup> has been available as a companion instrument to the TYPE 1130-A Digital Time and Frequency Meter.<sup>2</sup> The need for storage of the digital data has been discussed<sup>2</sup> previously. Storage facilities are built into the TYPE 1130 counter. The introduction of new digital instruments without storage has made it desirable to provide a new D-A converter with self-contained storage.

The new TYPE 1136-A Digital-to-Analog Converter has 3-decade BCD input, fast transfer into storage, and 0.1% over-all accuracy. Input data with 1-2-4-2 or 1-2-2-4 weighting is accepted; 1-2-4-8 weighting requires a minor modification; 10-line decimal input is accepted when an accessory, the TYPE 1136-P1 Diode Matrix and Cable, is used. Binary

"1" input must be at least 6 v positive with respect to binary "0". The actual voltage may be up to  $\pm 150$  v from ground. Maximum conversion rate is over 10 kc.

Up to 9 decades of 4-line BCD can be connected to the input, and a selector switch permits selection of any adjacent 3 or the last 2 to form the output. Illuminated indicators show which decades are selected.

### Principle of Operation

Figure 3 is a simplified schematic diagram. The input data is applied to the amplifiers  $A_1 \dots A_{12}$ . The gates  $G_1 \dots G_{12}$  are normally closed, and the input has no effect on the output

<sup>1</sup> H. P. Stratemeyer, "Analog Output from the Digital Counter," *General Radio Experimenter* (35, 10), October, 1961.

<sup>2</sup> R. W. Frank and H. T. McAleer, "A Frequency Counter with a Memory and with Built-In Reliability," *General Radio Experimenter* (35, 5), May, 1961.



switches (standardizers)  $S_1 \dots S_{12}$ . These electronic switches are self-latching and serve as storage elements for the input data. A storage-command pulse (SCP) is applied to the pulse generator (PG) and the gates  $G_1 \dots G_{12}$  are momentarily opened. This transfer system does not require any zero-set (clear) operation before new data is entered into storage.  $S_1 \dots S_{12}$  assume states corresponding to the input. The SCP is generated by the digital source at the beginning of the "display time." Most counters provide a suitable pulse output (print-command pulse). The total transfer time is about 30  $\mu$ sec.  $S_1 \dots S_{12}$  connect the weighting resistors to ground for binary 0 and to a precise voltage  $E$  for binary "1". The analog output is the sum of all the currents through  $R_1 \dots R_{12}$ . The 1 ma output is essentially a 15 v swing behind 15 k $\Omega$ .

**Accuracy — Linearity — Stability**

The impedance of the recorder does not affect the accuracy or the linearity of the output. The output matrix is shown in Figure 4.

Examination shows that, while the magnitude of  $I_o$  is affected by  $G_L$ , the relative contribution of each component is independent of  $G_L$ . The magnitude of  $I_o$

can be adjusted for the required full-scale value by adjustment of the supply voltage  $E$ .

The linearity of the output is determined by the accuracy of the weighting resistors, the precision of the electronic output switches, and the output impedance of the regulated power supply for  $E$  (see Figure 4).

The output switches are complementary pairs of inverted transistors. The offset voltage (the saturation voltage) is only 1 to 2 millivolts, and when  $E$  is over 15 volts this error does not exceed 0.02% of full scale. The variation of  $E$  as a function of the output current from the matrix is negligible.

The stability of the output is determined by the stability of the supply  $E$ , the weighting resistors, and the offset voltage. The largest contribution is the temperature coefficient of the zener-reference diode for the supply  $E$  (<10 ppm/ $^{\circ}$ C) and the temperature influence on the weighting resistors (<10 ppm/ $^{\circ}$ C referred to full scale).

In addition to these static errors there is a dynamic error as a function of transfer rate. Consider the change from 3 to 4 in 1-2-2-4 weighted BCD. The "3" output consists of a binary "1" in the first bit and in the second bit, i.e.,  $S_1$  and  $S_2$  are

**Figure 4. Equivalent circuit of the output matrix.**

$G_1 \dots G_{12}$  are the conductances of the weighting resistors  
 $S_1 \dots S_{12}$  the standardizer switches  
 $E_1 \dots E_{12}$  the voltages applied to the weighting resistors (0 v for a binary "0",  $E$  for a binary "1")  
 $G_L$  is the conductance of the recorder

$$E_o = \frac{\sum(E_n G_n)}{\sum G_n + G_L} \quad I_o = E_o G_L = G_L \frac{\sum(E_n G_n)}{\sum G_n + G_L}$$

$$I_o = \frac{G_L}{G_1 + G_2 + \dots + G_n + G_L} (E_1 G_1 + E_2 G_2 + \dots + E_n G_n)$$

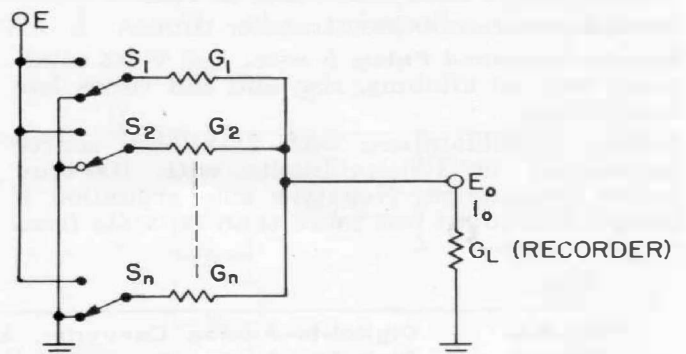

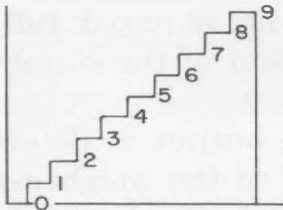

Figure 5a. Perfect output.

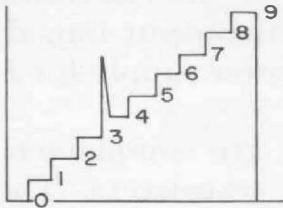

Figure 5b.  $S_4$  turns on before  $S_1$  and  $S_2$  are off.

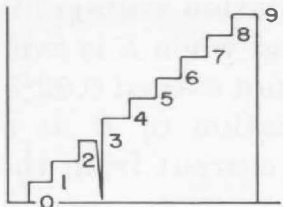

Figure 5c.  $S_4$  turns on after  $S_1$  and  $S_2$  have turned off.

on. To get the "4" output, the first and second bit have to change to binary "0" and the third bit to binary "1". In the

switching schematic this means that  $S_1$  and  $S_2$  have to turn off and  $S_3$  must turn on. Suppose that  $S_3$  turns on before  $S_1$  and  $S_2$  are off: then, during this "overlap" the output can be as high as 7, or, if  $S_3$  turns on after  $S_1$  and  $S_2$  have turned off, the output can momentarily drop to zero. Figure 5 illustrates this effect. The use of fast electronic switches keeps this time interval less than  $1 \mu\text{sec}$ . In the worst case this can contribute an output error of  $.0001\% \times$  conversion rate (in cps). The typical error is about three times less. In the worst case, at a conversion rate of 10,000 per second, this amounts to 1%. However, a recorder with response to 10 kc rarely has an accuracy of better than a few percent, so that this error can generally be neglected.

— H. P. STRATEMEYER

SPECIFICATIONS

**Data Input:** BCD weighted 1-2-4-2 or 1-2-2-4. Minor modification adapts for 1-2-4-8 input. Binary 1 at least 6 volts positive with respect to binary 0. Input impedance 50 kilohms. Binary 0 can be offset from ground by  $\pm 150$  volts. Switch selects any adjacent three or the last two digits of up to nine-decade input.

**Conversion Rate:** Up to 10,000 conversions per second (controlled by digital-measuring instrument).

**Over-all Accuracy:**  $\pm 0.1\%$  of full scale (includes repeatability, long-term stability, linearity,  $\pm 10\%$  line variation, and  $\pm 15 \text{ C}$  ambient-temperature variations around normal  $25 \text{ C}$ )  $\pm 0.0001\% \times$  conversion rate in cps.

**Storage Transfer:**  $50\text{-}\mu\text{sec}$  transfer time.

**Storage Command Pulse:**  $5 \mu\text{sec}$ ,  $\pm 6$  volts minimum into 10 kilohms, rise and fall times less than  $1 \mu\text{sec}$ .

**Output:** 1 milliamper with 15-kilohm source impedance, or 100 millivolts with 100-ohm source impedance. Negative side grounded if binary 0 or input not more than 20 volts from

ground. Output floating if offset voltage larger than 20 volts.

**Load:** 2000 ohms maximum for 1 milliamper output. 1000 ohms minimum for 100 millivolts output.

**Linearity:**  $\pm 0.05\%$  of full scale.

**Stability:**  $\pm 0.02\%$  for  $\pm 10\%$  line voltage;  $\pm 0.003\%$  of full scale per degree C.

**Accessories Supplied:** TYPE CAP-22 Power Cord, spare fuses.

**Accessory Available:** TYPE 1136-P1 Cable with diode-matrix, required for use with 10-line decimal data from General Radio counters of the 1150 series.

**Power Requirements:** 105 to 125 (or 210 to 250) volts, 50 to 400 cps, 7 watts.

**Cabinet:** Rack-bench.

**Dimensions:** Bench model — width 19, height  $3\frac{1}{2}$ , depth 12 inches (485 by 89 by 305 mm), over-all; rack model — panel 19 by  $3\frac{1}{2}$  inches (485 by 89 mm), depth behind panel 11 inches (280 mm).

**Net Weight:** 13 pounds (6 kg).

**Shipping Weight:** 17 pounds (8 kg).

Type		Code Number	Price
1136-AM	Digital-to-Analog Converter, Bench Model	1136-9801	\$650.00
1136-AR	Digital-to-Analog Converter, Rack Model..	1136-9811	650.00
1136-P1	Diode Matrix and Cable (for connection to TYPE 1150-AP or 1151-AP Counter).....	1136-9601	160.00

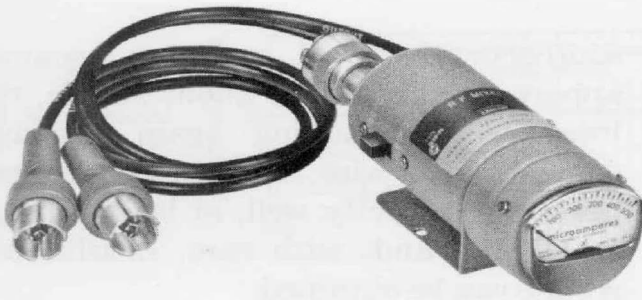

## TWO NEW MIXERS FOR THE DETECTION OF RF SIGNALS

A sensitive, well-shielded detector system is a basic requirement in most audio- and radio-frequency measurements. Detector sensitivity determines the resolution in null-type bridge measurements as well as in the measurement of high values of attenuation. In both these measurements, adequate shielding is a primary factor in determining the ultimate accuracy. Detectors of this description have been available from General Radio for most of the spectrum up to 4000 kc. These are:

- (1) The TYPE 1232-A Tuned Amplifier and Null Detector — 20 cps to 20 kc, with continuous coverage, plus 50 kc and 100 kc, fixed.
- (2) The TYPE 1212-A Unit Null Detector — 50 cps to 5 Mc, untuned; 1 Mc, tuned, with the TYPE 1212-P1 1-Mc Filter.
- (3) The TYPE DNT Detectors, which are heterodyne types, 40 to 4000 Mc.

### THE TYPE 1232-P1 RF MIXER

The circuit of the TYPE 1232-P1 RF Mixer is shown in Figure 1. Included are a microammeter for setting the level of the local oscillator and a high-Q tuned transformer to exclude the local-oscillator signal from the Tuned Amplifier and Null Detector.

Circuit elements are enclosed in an aluminum cylinder to which is appended, in a separate compartment, the meter housing. In addition, double-braid co-

Now two new rf mixers fill the gaps below 40 Mc. They operate by the heterodyne method, with low-frequency detector units serving as i-f amplifiers.

The heterodyne detector has a justly deserved preference over other types. It is currently the most convenient means of achieving high sensitivity, wide tuning range, and a high degree of harmonic rejection. It also has a great dynamic range because its amplification is essentially linear over 85-db of input-signal variation. Its disadvantages are few, but the principal one should be mentioned. In its simple form, no selectivity is provided in the signal input circuit, and so it can have some spurious responses from images and harmonics, which make it unsuitable for wave analysis. In general, these are not troublesome, and the addition of circuits to be tuned by the user would complicate the operation.

axial cable is used on all signal leads. As a result, the mixer is completely

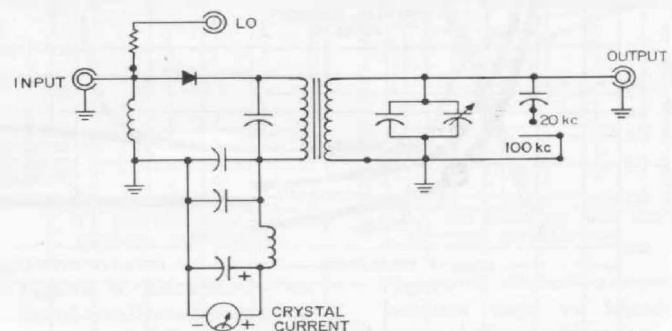

Figure 1. Schematic diagram of the mixer circuit.

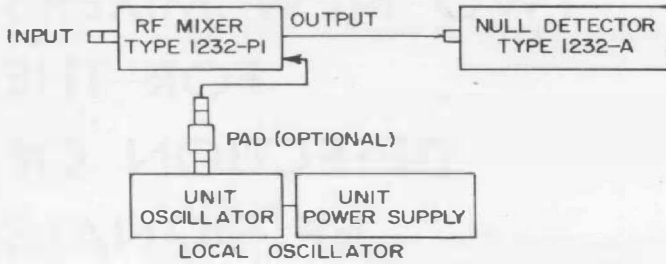

Figure 2. Block diagram of complete detector system using the Type 1232-P1 RF Mixer.

shielded from rf fields, thus preventing spurious null-balance indications.

In order to cover the range from 70 kc to 10 Mc, two i-f amplifier center-frequencies are required. One is 20 kc and is used to cover the range from 70 kc to 500 kc. Actually, the detector can be tuned continuously down to 25 kc, but sensitivity is reduced in this range, and spurious responses are more troublesome. Above 500 kc, the 20-kc frequency increment to which the local oscillator must be set is difficult to resolve, and the tuning is too critical. Therefore, above 500 kc, a switch is made to the 100-kc i-f circuit which is broader in bandwidth. The upper limit of 10 Mc was chosen because above this frequency it becomes difficult to set the 100-kc increment, and, again, the tuning becomes too sharp, so that any frequency drift of the signal

source or the local oscillator becomes apparent. Also, above about 20 Mc, the local-oscillator tuning again becomes critical. Otherwise, however, the mixer performs perfectly well, at least as high as 60 Mc, and, with care, satisfactory results can be obtained.

In practice the operation of the system is quite simple. Figure 2 is a block diagram of the complete detector system. The 20kc-100kc switch on the mixer is set to the desired frequency, and the corresponding frequency is switched-in on the TYPE 1232-A Null Detector. The local-oscillator output is set to produce the required mixer meter indication and the oscillator is then tuned to frequency by adjustment for maximum output indication in the TYPE 1232-A Tuned Amplifier and Null Detector when an external signal is introduced. For maximum sensitivity in the frequency range below 150 kc, the crystal current must be set to a particular value, as shown in Figure 3.

PERFORMANCE CHARACTERISTICS

The significant performance characteristics of the mixer are given in Figures 4 to 7. The linearity is shown as a function of input signal level in Fig-

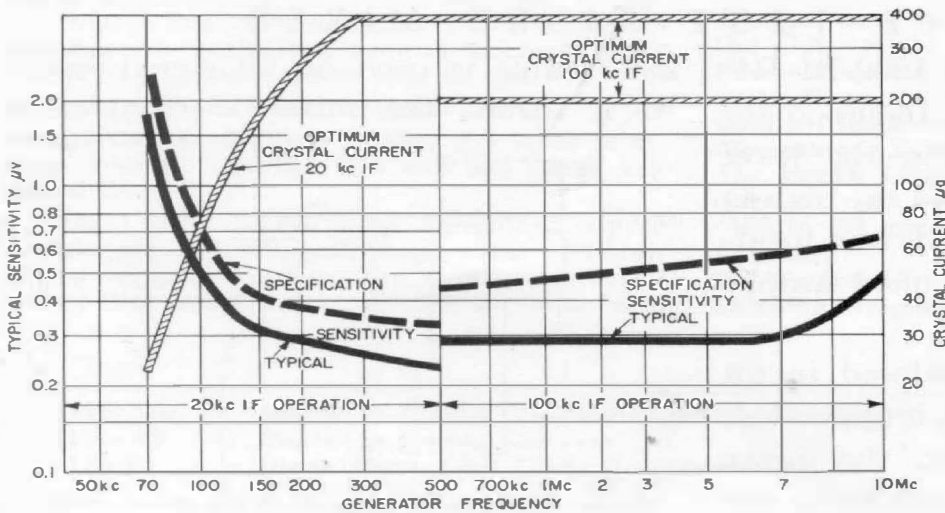
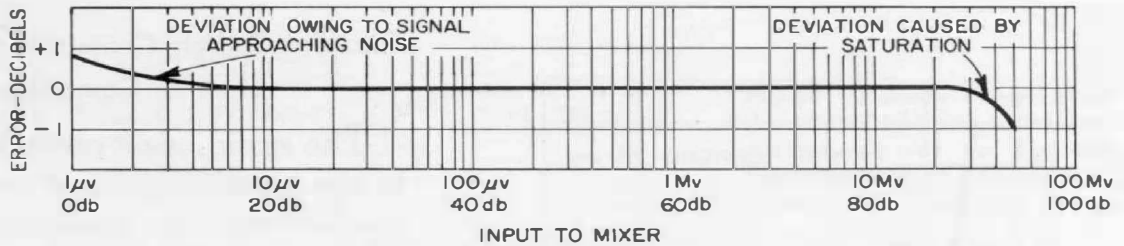

Figure 3. Sensitivity (open-circuit voltage from 50-ohm source, equivalent to noise level) and local-oscillator drive vs signal frequency.





**Figure 4. Linearity of the 1232-PL/1232-A detector as a function of input voltage.**



ure 4; it can be seen that above about 50-mv input an increase in input voltage produces a smaller-than-proportionate increase in output indication. The sensitivity, defined as the input signal voltage required to increase the output indication 3 db above the noise level, is shown in Figure 3. Other data of interest are given in Figure 5, which shows the sensitivity as a function of local-oscillator drive level, and in Figure 6, which shows the relative conversion loss also as a function of local-oscillator drive level. The degradation of sensitivity below the normal tuning range is shown in Figure 7. The mixer is still usable in this range, but local-oscillator feed-through produces a larger output indication.

**APPLICATIONS**

**Null Detector**

The combination of the TYPE 1232-P1 Mixer, the TYPE 1232-A Null Detector, and a local oscillator is an excellent bridge null detector for the frequency range from 70 kc to 10 Mc. Figure 8 is a block diagram of a complete bridge system using this detector, and a typical setup with the TYPE 916-AL Radio-Frequency Bridge is shown on the front cover.

**Attenuation Measurements, etc.**

This detector system is particularly well suited for the measurement of attenuation, especially high values of attenuation. For example, with a 100-mw source and reasonable padding (10 to

16 db at the detector) attenuation values as high as 120 db can be measured. A substitution method is employed wherein the attenuation to be measured is compared with a calibrated adjustable attenuator, such as the TYPE 874-GA. The TYPE 1232-A Tuned Amplifier and Null Detector is used as level indicator, since it does not have its own calibrated attenuator. For maximum resolution in these measurements it is essential that the detector circuits be operated within their linear range. Detector linearity for the 1232-P1/1232-A combination is shown in Figure 4, and applies for all diode-current levels above 200  $\mu$ a. Figure 9 is a block diagram of the measuring setup.

Attenuation of 10 db or less can be measured with an accuracy of  $\pm \frac{1}{20}$  of the db increment being measured by use of the db scale on the meter of the null detector. In this measurement, linearity at both the lowest and highest usable input-signal extremes, for the detector, are important. The usable input-signal

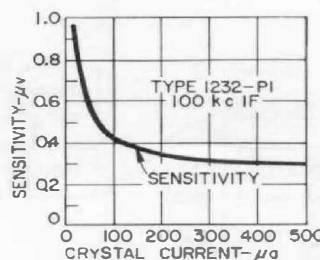

**Figure 5. Sensitivity vs local-oscillator drive for 100-kc intermediate frequency.**

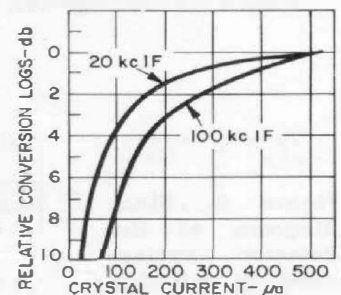

**Figure 6. Relative conversion loss vs local-oscillator drive.**

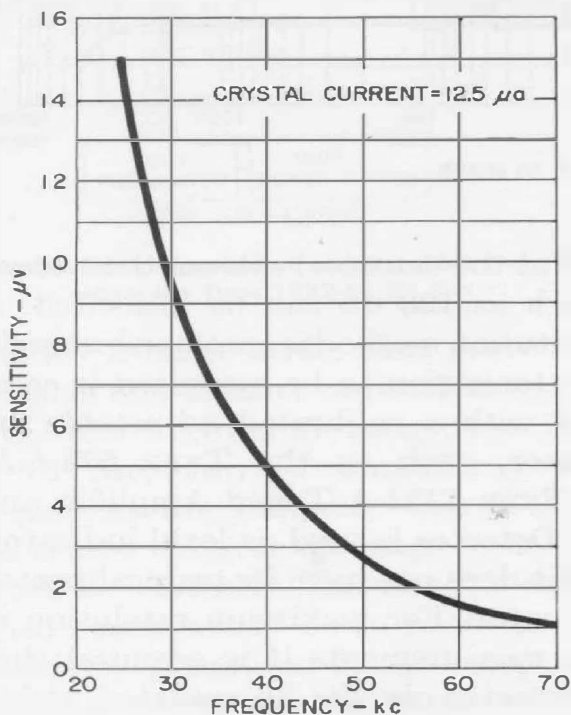

Figure 7. Typical sensitivity at frequencies below normal range.

range can be determined from Figure 4. The deviation from linearity at low levels arises from the relative contribution of the amplifier noise in the output indication, when the signal-to-noise ratio is small.

- Specific attenuation measurements to which this procedure is applicable are:
- Attenuator or network insertion loss
  - Filter stop-band response
  - Coaxial cable loss<sup>1</sup>
  - Coaxial switch cross-talk
  - Coaxial cable or connector leakage<sup>2</sup>

### Coaxial Switch Crosstalk or Multiport Component Measurements

The same basic procedure can be used in the measurement of crosstalk between connections in multiport components, such as coaxial switches, semiconductor switches, and duplexers or multiplexers.

The component to be measured is, for example, driven at its input and the "through" channel (the output connection to which the input is intended to produce an output signal) is terminated in a matched termination, or other desired impedance, depending on the impedance with which the device is normally terminated. The other unused ports are similarly terminated. The detector is connected to the port in which crosstalk is to be measured, and the attenuation with this connection is measured by the substitution method. In the substitution method, a known amount of attenuation is inserted to produce the same output indication that was produced with the component installed.

Most systems operate at a nominal impedance of 50 ohms. The mixer input impedance is about 200 ohms. It can be made very nearly 50 ohms by the addition of an 874-G10 10-db attenuator at its input.

For operation at other than the 50-ohm level, transformers are required.

Figure 8. Block diagram of the detector system used as a bridge null detector.

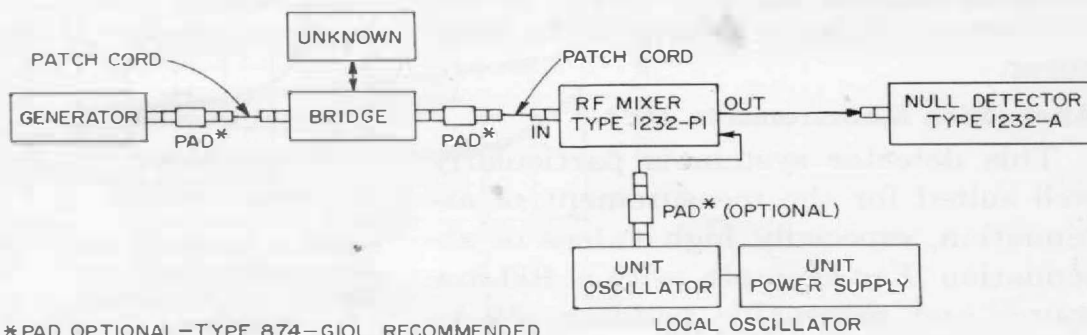

\*PAD OPTIONAL—TYPE 874—GIOL RECOMMENDED

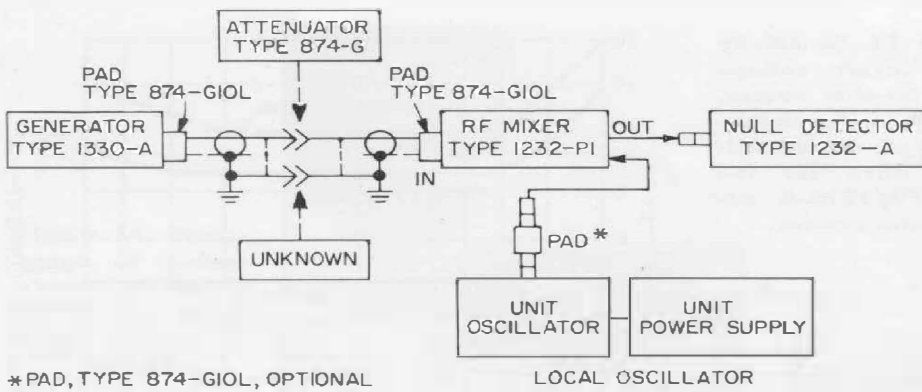

Figure 9. Block diagram of the 1232-P1/1232-A detector system as set up for the measurement of attenuation.

\*PAD, TYPE 874-GIOL, OPTIONAL

LOCAL OSCILLATOR

### Cable Connector or Leakage Measurements

The leakage or shielding effectiveness of cables or connectors can also be measured by the same procedure as for attenuation measurements. A special test

fixture is required in this case. Specific details of this fixture and the procedure are described in the reference cited.<sup>2</sup>

<sup>1</sup> W. R. Thurston, "The Measurement of Cable Characteristics," General Radio Reprint No. E-104.

<sup>2</sup> J. R. Zorzy & R. F. Muehlberger, "R-F Leakage Characteristics of Popular Coaxial Cables and Connectors, 500 Mc to 7.5 Gc," *Microwave Journal*, November, 1961, General Radio Reprint No. A-93.

### SPECIFICATIONS

**Frequency Range:** 70 kc to 10 Mc. (Can be used up to 60 Mc, with care in the selection and identification of local-oscillator frequencies.)  
**I-F Output Frequencies:** Switch-selected to 20 kc or 100 kc.  
**Bandwidth:** 0.8 kc in 20-kc position, 10 kc in 100-kc position with a 20-kilohm output load (TYPE 1232-P1 RF Mixer alone).

**Sensitivity:** See Figure 3.  
**Input Impedance:** Approximately 200 ohms.  
**Output Impedance:** Approximately 20,000 ohms.  
**Dimensions:** Diameter 2¼, length 6¾ inches (58 by 175 mm).  
**Net Weight:** 1 pound (0.5 kg).  
**Shipping Weight:** 2 pounds (1 kg).

Type		Code Number	Price
1232-P1	RF Mixer	1232-9601	\$105.00

### TYPE 1212-P3 RF MIXER

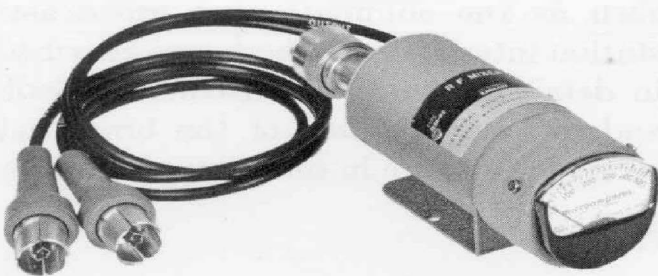

The 1212-P3 RF Mixer is essentially of the same construction as the 1232-P1, differing principally in the choice of i-f center frequency, 1 Mc. The circuit is shown in Figure 10. With the 1212-A Unit Null Detector, the lowest frequency of operation is 3 Mc. Below this, the

local-oscillator signal feeds through directly into the Unit Null Detector, producing a meter indication in spite of the filter networks provided in the mixer unit. The highest frequency of operation,

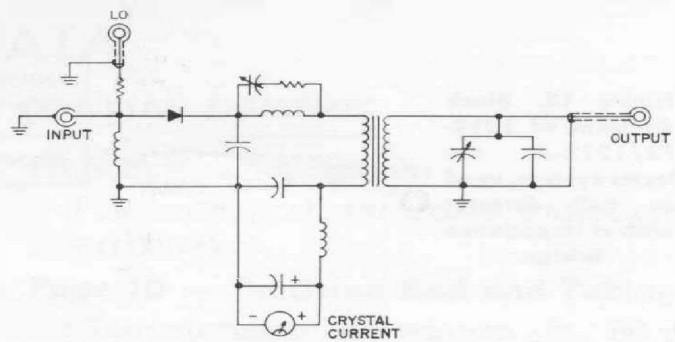

Figure 10. Schematic of the Type 1212-P3 RF Mixer.

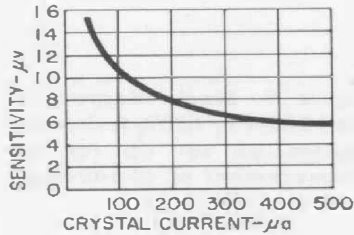

Figure 11. Sensitivity (open-circuit voltage from 50-ohm source, for 1% meter deflection) vs local-oscillator drive for the 1212-P3/1212-A detector system.

again limited by local-oscillator tuning resolution, tuning difficulty, etc., is 60 Mc. Aside from these considerations, the mixer performs perfectly well up to at least 150 Mc.

**Null Detector**

The response of the Unit Null Detector is approximately logarithmic, rather than linear. For this reason, it does not have a gain control. The system, is, therefore, usable only as a null detector, and, in this application, it is a sensitive, easy-to-use instrument. The principal characteristics of interest are the variation of sensitivity with diode current (Figure 11) and sensitivity over the frequency range (Figure 12).

Figure 13 is a block diagram of the detector shown as part of a complete rf bridge system. The local oscillator is always set higher than the generator frequency when the operating frequency is below 10 Mc, in order to minimize the local-oscillator voltage that gets through to the mixer output.

**Use with a Broadcast Receiver**

The TYPE 1212-P3 Mixer can also be used with a standard broadcast receiver

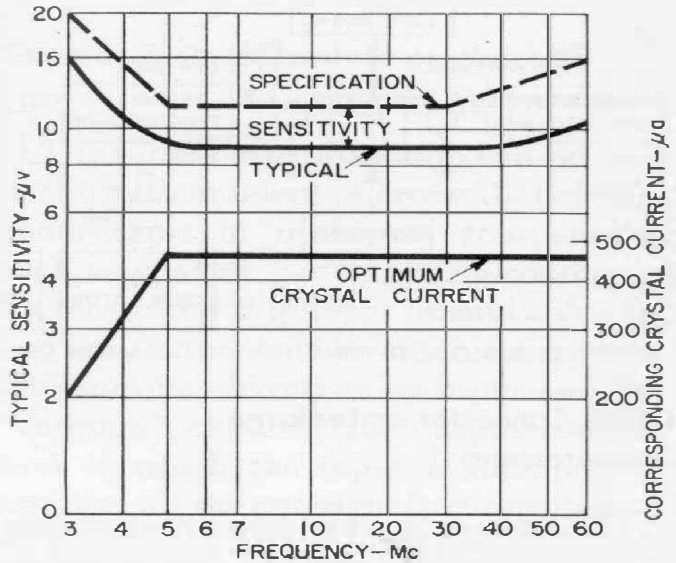
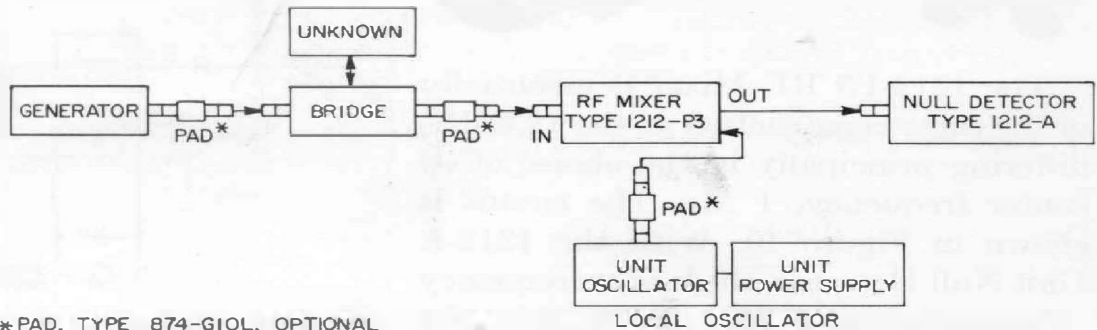

Figure 12. Sensitivity vs frequency.

in place of the Unit Null Detector. Here, the generator can be modulated in order to obtain an aural null indication. The sensitivity characteristics shown in Figure 13 apply to this application also with one exception: the 9- $\mu v$  sensitivity value extends to a lower frequency limit, approximately 1.5 Mc. Therefore, with a broadcast receiver set at 1 Mc, a tunable detector from 0.54 Mc to 60 Mc is obtained (if we include the 0.54 to 1.5 Mc range of the receiver itself). There are, however, several precautions to be taken, such as the elimination of broadcast-station interference. These are described in detail in the mixer instruction book and include shielding of the broadcast receiver and care in selection of the gen-

Figure 13. Block diagram of 1212-P3/1212-A detector system, used as null detector with rf impedance bridge.



\*PAD, TYPE 874-GIOL, OPTIONAL



**Figure 14. Photograph of system shown in Figure 14. Bridge is the Type 1606-A RF Bridge.**

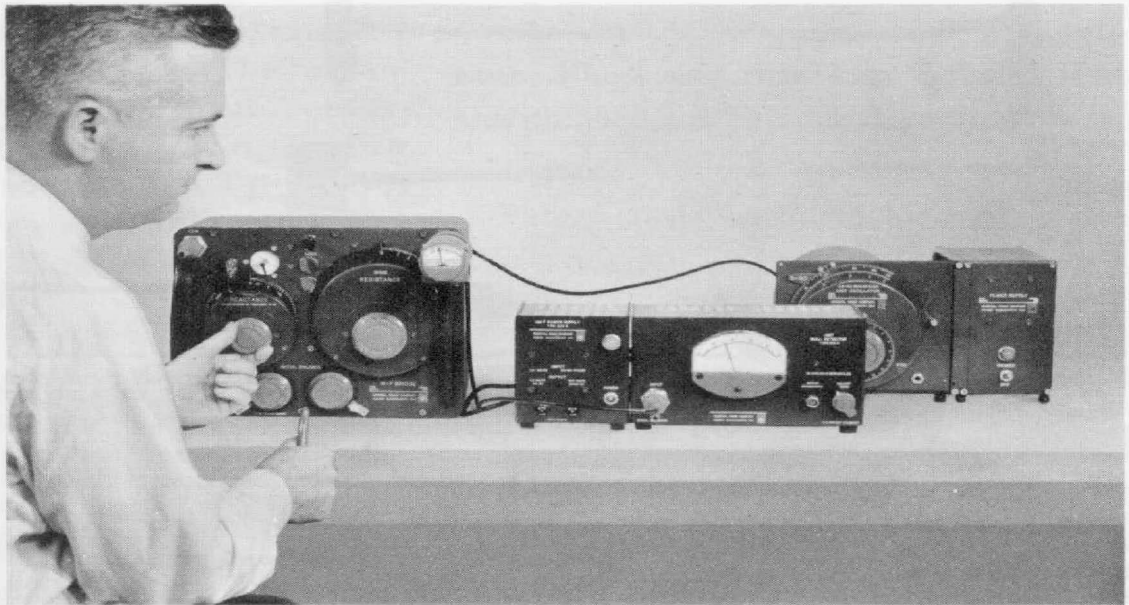

erator frequency to avoid tuning to harmonics of the receiver local oscillator. A transistor portable makes a good receiver for this application, because its small size permits it to be easily sur-

rounded by a complete shield.

The combination of the detector and the TYPE 1606-A Radio-Frequency Bridge is shown in Figure 14.

— J. ZORZY

**SPECIFICATIONS**

**Frequency Range:** 3 Mc to 60 Mc. (Can be used up to 150 Mc if care is taken in the selection and identification of local-oscillator frequency.)  
**I-F Output Frequency:** 1 Mc.  
**Bandwidth:** 25 kc with TYPE 1212-A Unit Null Detector.  
**Sensitivity:** See Figure 12.  
**Input Impedance:** Approximately 200 ohms.

**Output Impedance:** Approximately 50 kilohms.  
**Terminals:** TYPE 874 Coaxial Connector at end of cable.  
**Dimensions:** Diameter 2¼, length 6¾ inches (58 by 175 mm).  
**Net Weight:** 1 pound (0.5 kg).  
**Shipping Weight:** 2 pounds (1 kg).

Type		Code Number	Price
1212-P3	RF Mixer . . . . .	1212-9603	\$105.00

**ERRATA**

**TYPE 900 PRECISION COAXIAL ELEMENTS**

In the maze of type numbers, tolerances, and tabulations describing this equipment in our November issue, a couple of errors crept in, unnoticed until too late. Since these relate to important specifications, we hasten to correct them.

**Page 8, first paragraph:**

Tolerance on characteristic impedance is  $\pm 0.065\%$ .

**Page 10 — Precision Rod and Tubing:**

Characteristic impedance is  $50 \pm 0.0325$  ohms (0.065%).

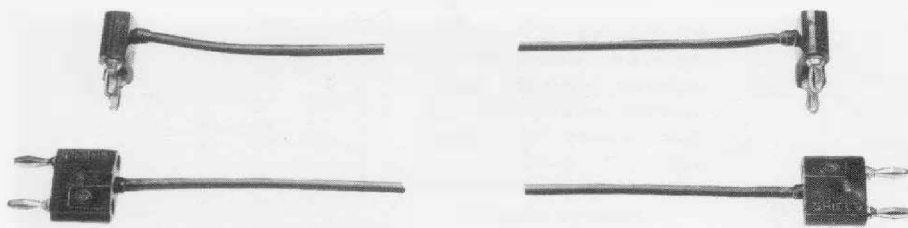

Figure 1. New double-plug patch cords with straight-through and right-angle connections. Each type is available in 1-, 2-, or 3-foot lengths.



Figure 2. Recess in body of new double plug means any two plugs can be stacked.



Figure 3. New single-plug patch cord, available in red or black and in 9-, 18-, or 36-inch length.

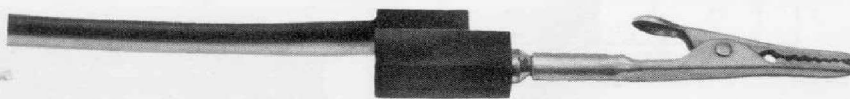

Figure 4. Alligator clip slips over single plug to convert plug lead to clip lead.

## A NEW PLUG FOR PATCH CORDS

Although known primarily as an instrument manufacturer, General Radio has developed many components and parts that achieved industry-wide popularity. Notable among these was the "banana" plug, introduced in this country by GR in 1924 and manufactured ever since by us as the TYPE 274 Plug. The present crop of banana plugs includes single, double, insulated, and shielded varieties. Two patch cords, each consisting of TYPE 274 double plugs molded on both ends of a shielded cable, have also been available.

A new lineup of 12 TYPE 274 Patch Cords offers (1) a new, improved double plug, (2) a choice of straight-through or right-angle connection to the plug, (3) a wider choice of lead lengths, and (4) new single-plug patch cords.

The new double plug consists of two banana plugs, one gold-plated and one nickel-plated, whose soldered ends are encapsulated first in polystyrene (for its electrical qualities) and then in cellu-

lose-acetate butyrate (for its high-impact properties). At the other end of the connector body are two banana-plug jacks, and the configuration of the connector is such that any double plug can be connected to any other, regardless of whether the plugs have straight-through or right-angle connections (see Figure 2).

The gold and nickel color coding of the banana plugs is in accordance with electrical wiring conventions (the nickel is the shield, or ground connector). In addition, the word SHIELD is clearly marked next to the shield terminal.

Double-plug patch cords are now available in 1-, 2-, and 3-foot lengths, with either straight-through or right-angle connections. Leads are made of low-capacitance, flexible coaxial cable.

The single-banana-plug patch cord is shown in Figure 3. It is available in either red or black and in three lengths: 9, 18, and 36 inches. The connector body



is molded cellulose-acetate butyrate and includes a jack for stacking. The banana plug's versatility allows quick conversion of the patch cord to an alligator clip lead by the addition of a TYPE 838-B Alligator Clip, as shown in Figure 4.

All TYPE 274 Plugs and Jacks have a

contact resistance in the order of 1 milliohm. Plugs seat firmly in jacks so that the plug springs are not depended on for mechanical stability.

Patch cords with shielded plugs are also available, as listed below.

<i>Type</i>	<i>Description</i>	<i>Part No.</i>	<i>Price</i>
274-LLB	Single-Plug Patch Cord, 36-inch, black . . . . .	0274-9468	\$1.25
274-LLR	Single-Plug Patch Cord, 36-inch, red . . . . .	0274-9492	1.25
274-LMB	Single-Plug Patch Cord, 18-inch, black . . . . .	0274-9847	1.25
274-LMR	Single-Plug Patch Cord, 18-inch, red . . . . .	0274-9848	1.25
274-LSB	Single-Plug Patch Cord, 9-inch, black . . . . .	0274-9849	1.25
274-LSR	Single-Plug Patch Cord, 9-inch, red . . . . .	0274-9850	1.25
274-NP	Double-Plug Patch Cord, 3-foot, side connection	0274-9880	3.50
274-NP M	Double-Plug Patch Cord, 2-foot, side connection	0274-9892	3.50
274-NPS	Double-Plug Patch Cord, 1-foot, side connection	0274-9852	3.50
274-NQ	Double-Plug Patch Cord, 3-foot, end connection	0274-9860	3.50
274-NQ M	Double-Plug Patch Cord, 2-foot, end connection	0274-9896	3.50
274-NQS	Double-Plug Patch Cord, 1-foot, end connection	0274-9861	3.50
274-NL	Shielded Double-Plug Patch Cord, 3-foot . . . . .	0274-9883	4.50
274-NL M	Shielded Double-Plug Patch Cord, 2-foot . . . . .	0274-9882	4.50
274-NLS	Shielded Double-Plug Patch Cord, 1-foot . . . . .	0274-9862	4.50

## HANDBOOKS TO HELP YOU

The *Handbook of Noise Measurement* first appeared in 1953 and met with wide acclaim from expert and tyro alike. It brought together in one convenient booklet a wealth of definitions, data, and procedures for the measurement of noise in industry. This handbook has been rewritten and revised with each successive edition, to keep pace with changing standards and new devices. The new fifth edition is a complete and authoritative treatise, full of useful information for those who need to measure acoustical noise — whether product noise, environmental noise, or the transient noise of passing vehicles.

The *Handbook of Noise Measurement* is priced at one dollar (\$1.00), postpaid, which is substantially less than it costs us to print and mail it. Size, 6 x 9 inches, 256 pages, an outstanding bargain!

A new handbook has just appeared on the scene, the *Handbook of High-Speed Photography*. This is a compendium of principles and methods of the photographing of objects moving at high speeds. The light sources considered are General Radio stroboscopes, which produce light flashes of one microsecond or less. Objects moving faster than the speed of sound can be recorded on film by these light sources. This 56-page booklet is full of detailed procedures, useful to both professional and amateur. Size, 6 x 9 inches, 56 pages. Free upon request.

*The Handbook of Voltage Control*, published earlier this year, is designed to help you get the most from your Variac® adjustable autotransformer. Theory, circuits, and applications are covered. Size, 8½ x 11 inches, 40 pages. Free upon request.



## CHARLES C. CAREY

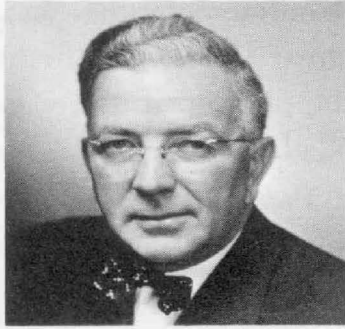

Charles C. Carey, late President of this company, came to General Radio in 1927. In 1931 he was made Assistant to the Vice-President for Production; in 1934, Production Superintendent; in 1944, Vice-President for Production; in 1950, a Director of the Company; and in 1956, President.

An alumnus of Boston University and Northeastern University, he was a director of the National Shawmut Bank

and a trustee of Northeastern University.

His talents were many, and his interests ranged over many fields. Most important at employee-owned General Radio was Mr. Carey's constant interest in all employees, their successes, and their problems.

Among his many contributions to our Company were his planning and execution of our several expansion programs during and since World War II, including the transfer of all operations from Cambridge to the present site in Concord and our current expansion into a new plant in Bolton, Mass.

On October 17, Charles Carey died at the age of 58. We who were enriched by his 36-year career with GR are saddened by his death.



## DONALD B. SINCLAIR

General Radio's new President, elected by the Directors on October 18, is Donald B. Sinclair.

Dr. Sinclair was born in Winnipeg, Manitoba, in 1910, attended the University of Manitoba from 1926 to 1929, then transferred to the Massachusetts Institute of Technology, where he received degrees of SB in 1931, SM in 1932, and ScD in 1935. He joined General Radio in 1936 and subsequently became Chief Engineer. In 1955 he was appointed Vice-President for Engineering and in 1956 was elected a Director. For the past two years he has held the post of Executive Vice-President and Technical Director.

During World War II Dr. Sinclair was in charge of the search receiver work for radar countermeasures at the Radio Research Laboratory at Harvard University, and he was a member of Division Five of the National Defense Research Committee on Guided Missiles. For his work on countermeasures and guided missiles, he received the President's Certificate of Merit in 1948. From 1954 to 1958 he was a member of the Technical Advisory Panel on Electronics of the Department of Defense.

Dr. Sinclair is a Fellow of the IEEE, and was President of the IRE in 1952, following a term as Treasurer in 1949-50. He served on the Executive Committee of the IRE in 1948-1950 and again in 1952-1953, and was on the Board of Directors from 1945 to 1954 and in 1958. He is also a member of Sigma Xi, Eta Kappa Nu, the American Association for the Advancement of Science, the American Physical Society, and the Instrument Society of America.